

FREIRAUM UND GRÜN - DIE BESTEHENDE UND NEUE GEBÄUDE DAZWISCHEN

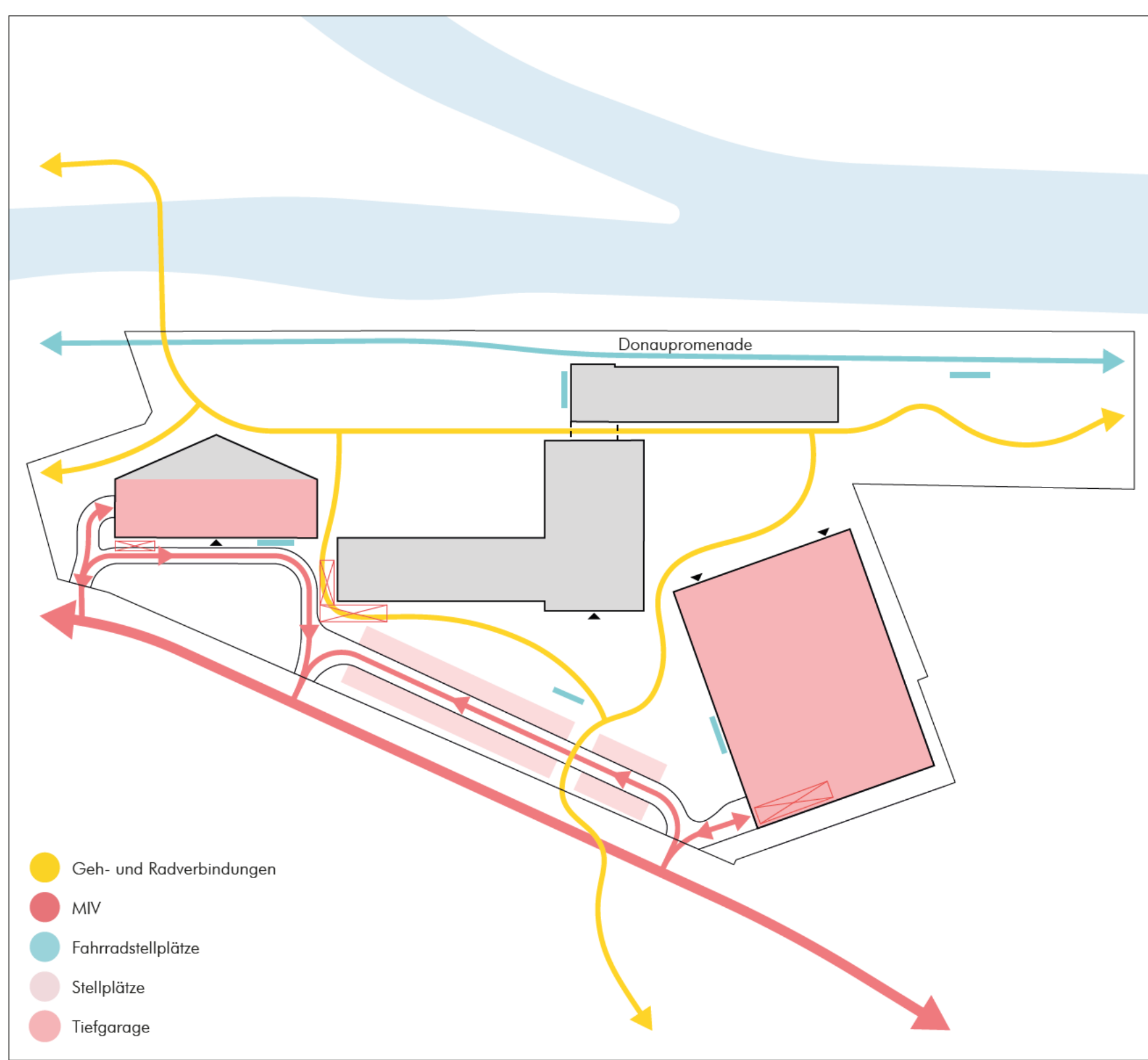

ERLÄUTERUNG DES MOBILITÄTSKONZEPTE



CHARAKTER DES ÖFFENTLICHEN RAUMS

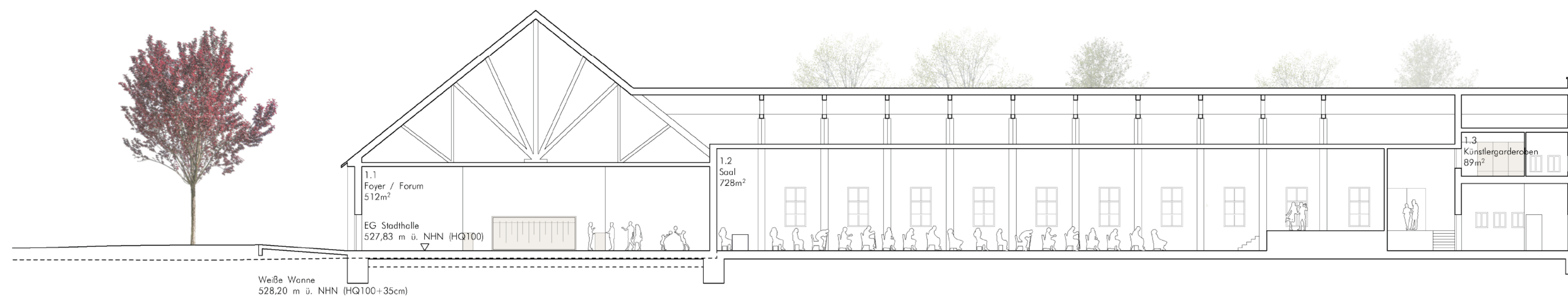

LÄNGSSCHNITT S1 M.1:200



QUERSCHNITT S2 M.1:200

2.0	2.1	2.3	2.5	2.5	2.5	2.5	2.5	2.5	2.5	+14,65
Gastzimmer	Gastzimmer	Gastzimmer	Gastzimmer	Gastzimmer	Gastzimmer	Gastzimmer	Gastzimmer	Gastzimmer	Gastzimmer	▽
32m²	32m²	32m²	32m²	32m²	32m²	32m²	32m²	32m²	32m²	+11,50
2.9	2.9	2.9	2.9	2.9	2.9	2.9	2.9	2.9	2.9	▽
Gastzimmer	Gastzimmer	Gastzimmer	Gastzimmer	Gastzimmer	Gastzimmer	Gastzimmer	Gastzimmer	Gastzimmer	Gastzimmer	+8,35
32m²	32m²	32m²	32m²	32m²	32m²	32m²	32m²	32m²	32m²	▽
2.5	2.5	2.6	2.6	2.6	2.6	2.6	2.6	2.6	2.6	+5,20
Gastzimmer	Gastzimmer	Administration	Administration	Administration	Administration	Administration	Administration	Administration	Administration	▽
32m²	32m²	66m²	61m²	61m²	61m²	61m²	61m²	61m²	61m²	+1,20
2.3	2.3	2.2	2.1	2.2	2.2	2.7	2.7	2.7	2.7	▽
Technik- f.	EG Hotel	Backoffice	Tropfenberechnungs-	Toiletten	Toiletten	Technik	Technik	Technik	Technik	-1,20
15m²	327,20 m² u. N.N.	15m²	Lobby	29m²	29m²	30m²	30m²	30m²	30m²	-1,95
Parkierung	452m²									▽

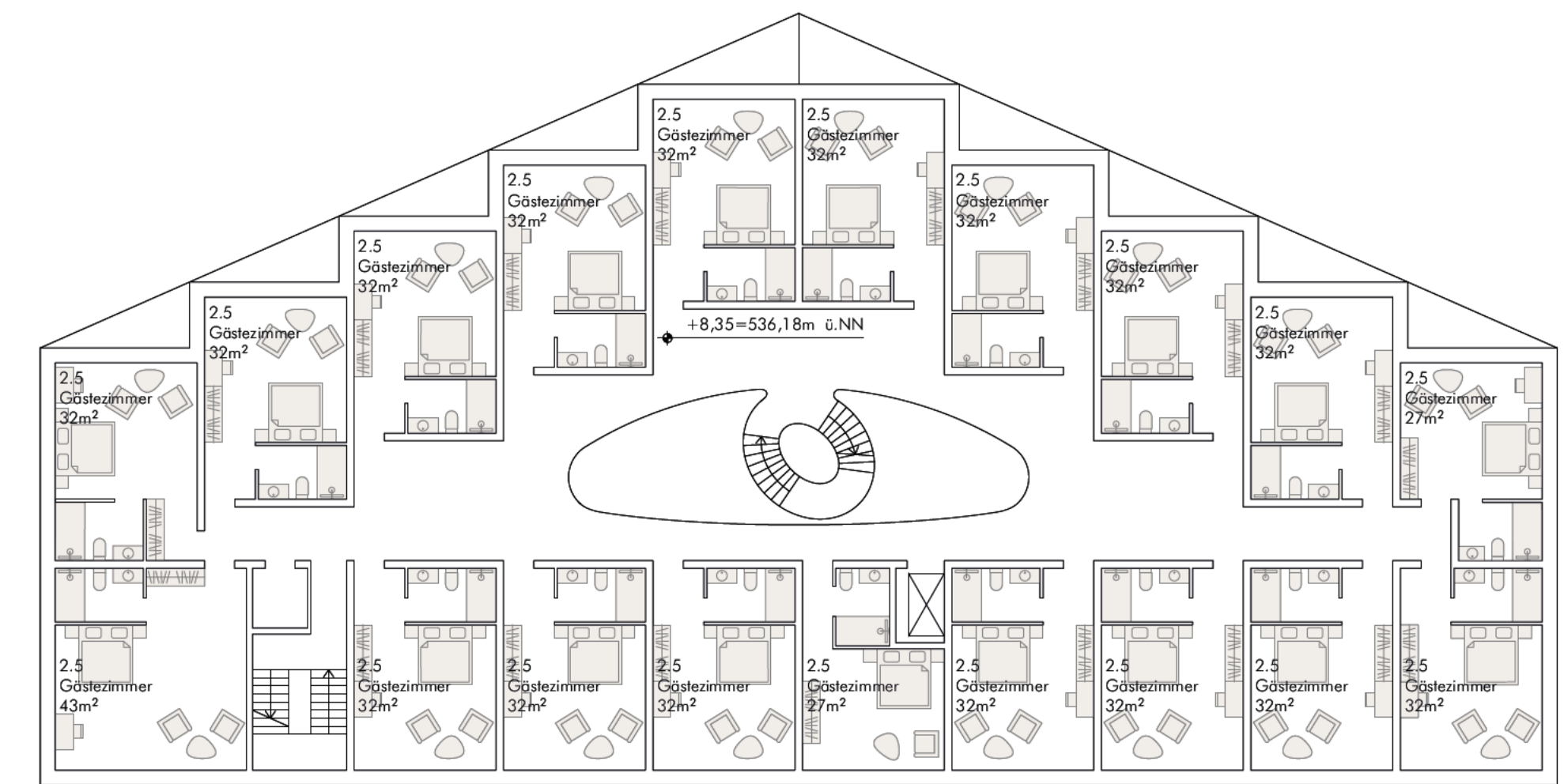

GRUNDRISS HOTEL 2. UND 3. OG M.1:200

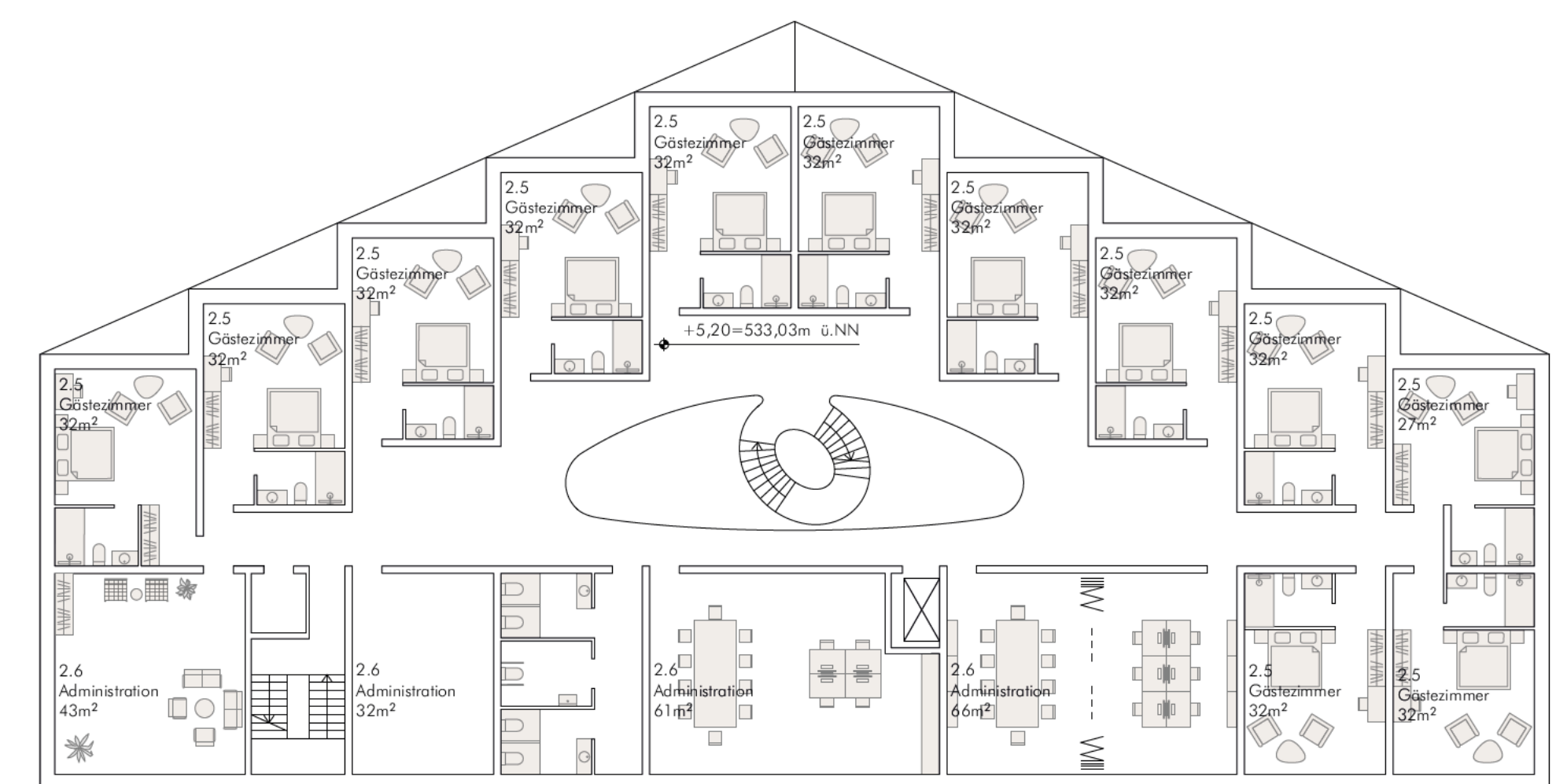

GRUNDRISS HOTEL 1. OG M.1:200

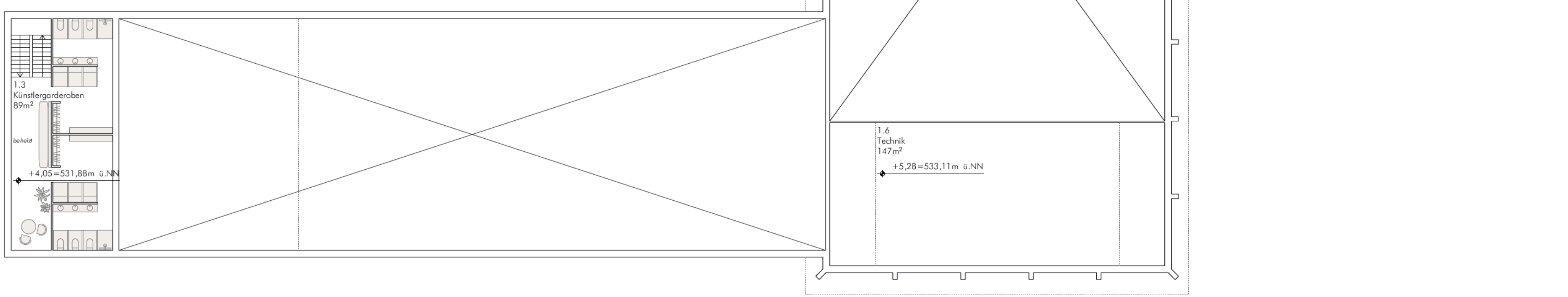

GRUNDRISS STADTHALLE, VERSTEIGERUNGSHALLE UND BULLENSTÄLLE 1. OG M.1:200

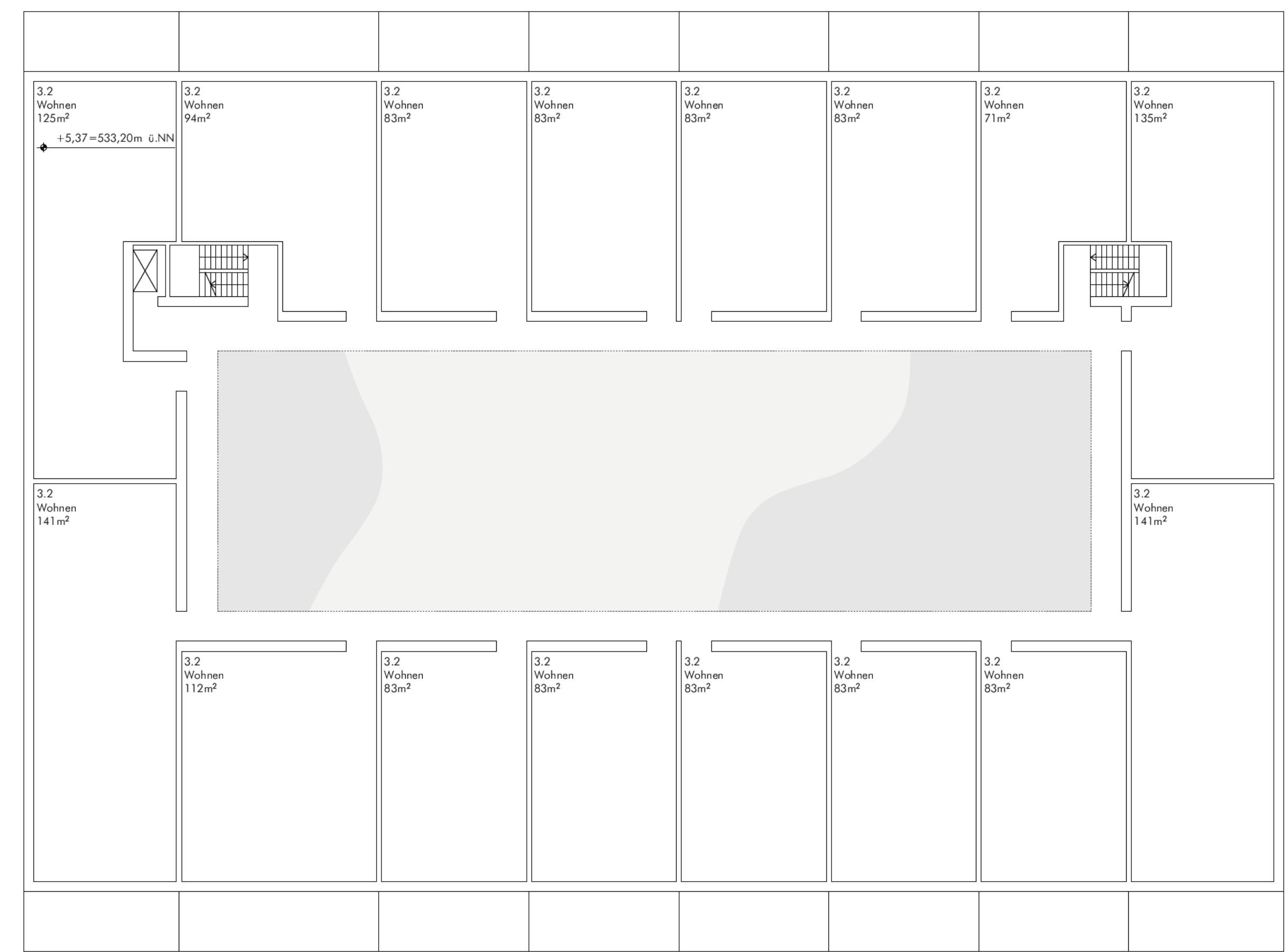

GRUNDRISS VERBRAUCHERMARKT UND WOHNEN 1. OG M.1:200

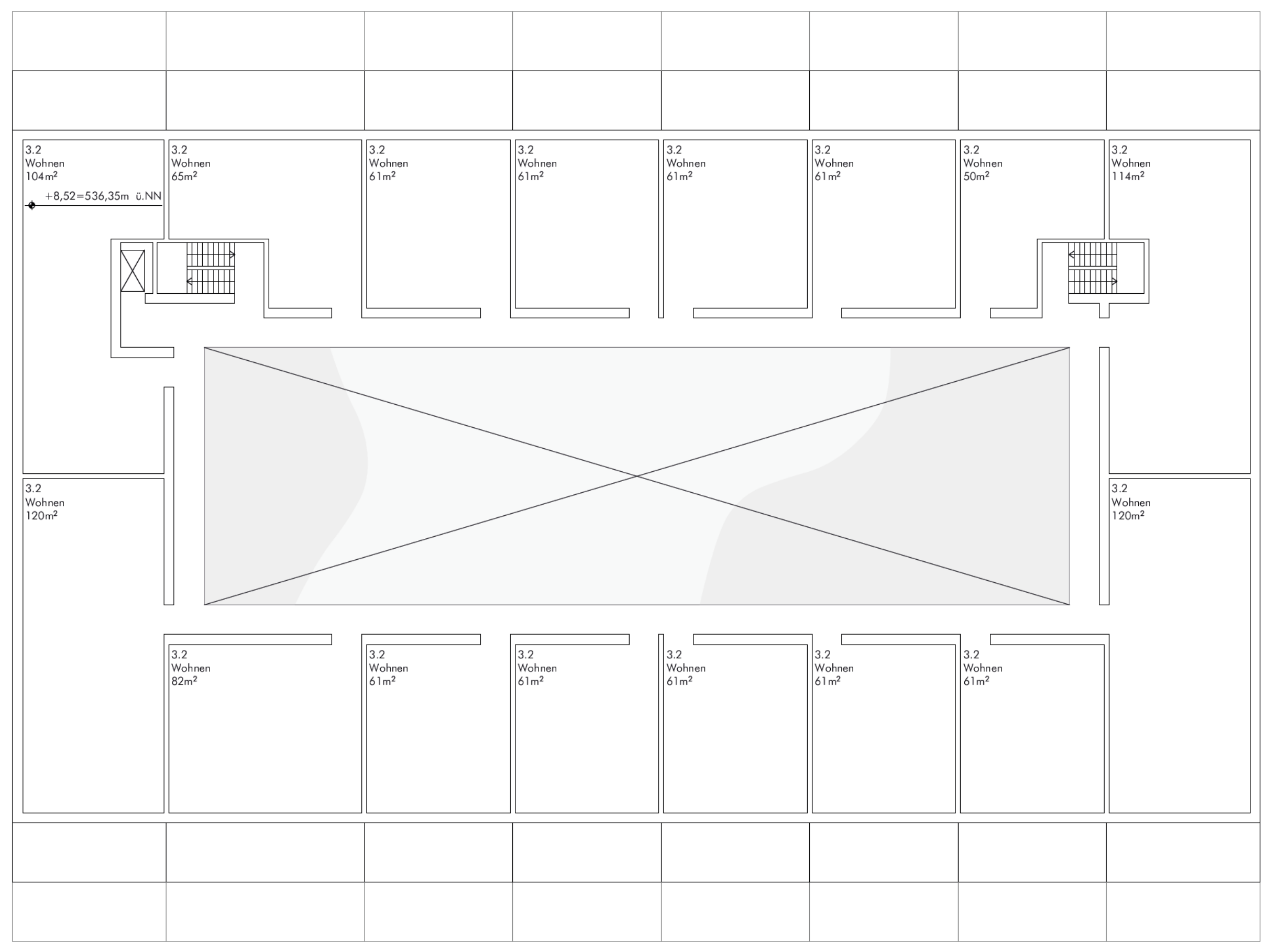

GRUNDRISS VERBRAUCHERMARKT UND WOHNEN 2. OG M.1:200